

MotorGuide® REPAIR PARTS

Model: MAGNUM
752V

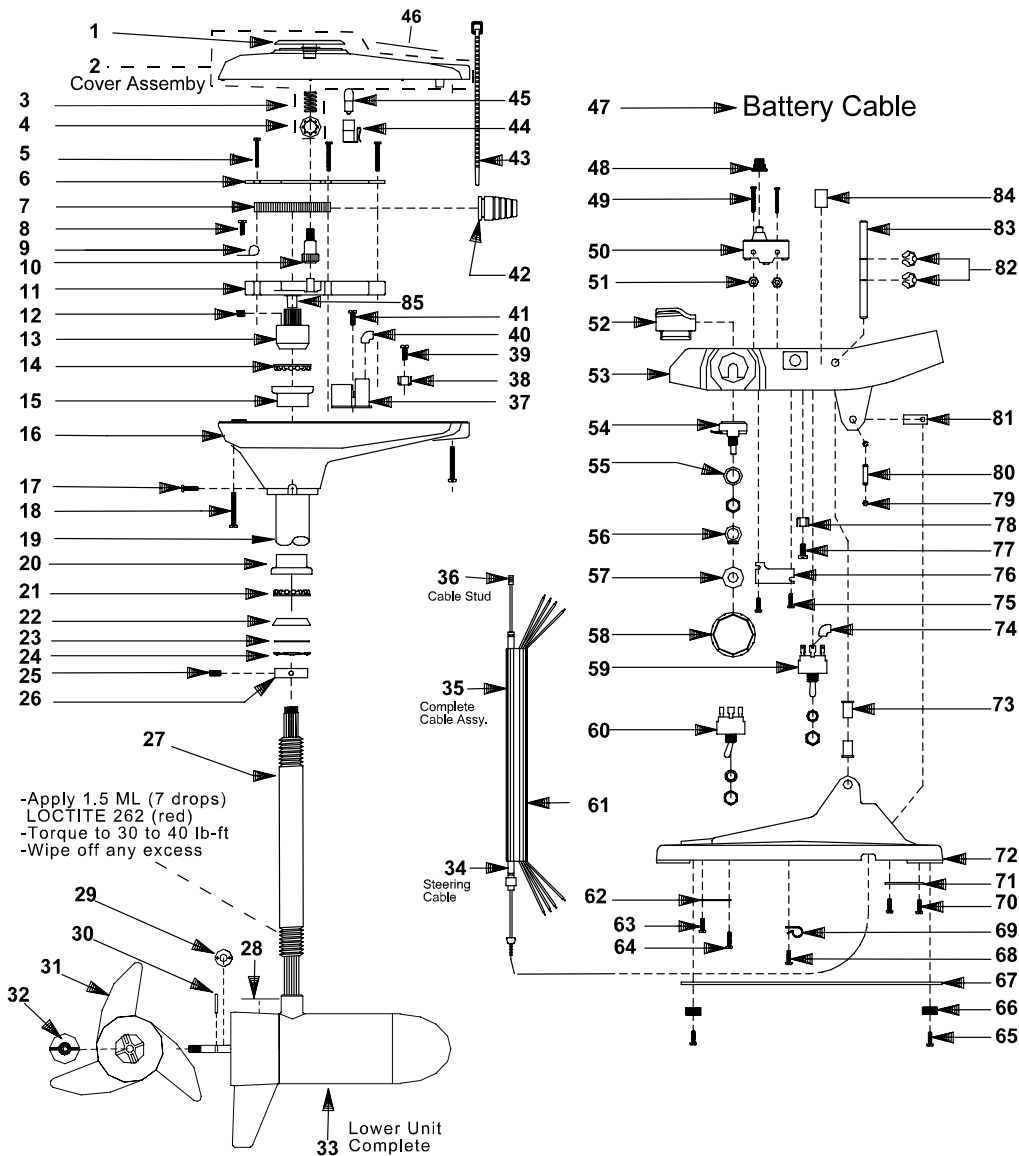

-Apply 1.5 ML (7 drops)
LOCTITE 262 (red)
-Torque to 30 to 40 lb-ft
-Wipe off any excess

SPECIFICATIONS:

Year of Intro 1999
Thrust 52 LBS
Volts 12VDC
Amp Draw 0 to 48 amps
Mount 15 Bow
Speeds Variable

QUICK REFERENCE PARTS GUIDE:

Momentary switch AP151-01
Toggle Switch FP153-03
DA Board JF157-03
MOSFET JF096-08
Motor Seal Kit 6220

PARTS ORDERING & TECH ASSISTANCE

MotorGuide Consumer Relations
Phone 918-831-6989
Fax 800-982-8093

KEY	DESCRIPTION	PART #	KEY	DESCRIPTION	PART #	KEY	DESCRIPTION	PART #
1	RED INDICATOR	AF078-08	29	MONOFILAMENT WASHER	AR175-01	57	NYLON WASHER	AK171-02
2	T/H COVER COMPLETE BLACK	AF053-13	30	PROP DRIVE PIN	BR102-01	58	VARIABLE SPEED KNOB	LP082-06
	T/H COVER COMPLETE WHITE	AF053-12	31	PROP/ 2 BLADE	AF124-07	59	TOGGLE SWITCH 3 POSITIONS	FP153-03
3	COMPRESSION SPRING	AF014-01	32	PROP NUT	AR099-01			
4	TINNERMAN CLIP	AF046-01	33	F/O MOTOR WR	CF397-16	61	69" ELECTRIC CABLE JACKET	MM9006-03
5	#6 RACK GUIDE SCREW	AF133-01	34	63" CONTROL CABLE STUD ASY	9377		63" ELECTRIC CABLE JACKET	MM9006-02
6	RACK GUIDE COVER	AF127-01		69" CONTROL CABLE STUD ASY	9767	62	CABLE PLATE	KP123-01
7	RACK	AP125-01	35	63" CONTROL CABLE ASY	AP327-16	63	#6 SELF TAP SCREW	EK135-01
8	#10 x 1/2" SCREW	GR133-01		69" CONTROL CABLE ASY	AP327-18	64	6 X 1/2 SCREW	AF135-01
9	CABLE CLAMP	AP036-01	36	CONTROL CABLE STUD	AP141-01	65	6 X 1/2 SCREW	AF135-01
10	INDICATOR GEAR	AF069-01	37	12 VOLT DURA AMP BOARD	JF157-03	66	FOOT PEDAL PAD	KP023-01
11	RACK GUIDE	AF126-01	38	TERMINAL (4 PRONG)	FT160-03	67	WEIGHT PLATE ASY	LP3123-01
12	1/4 NUT SET SCREW	AF142-01	39	#10 x 1/2" SCREW	GR133-01	68	6 X 1/2 SCREW	AF135-01
13	PM PINION NUT	AF398-01	40	INSULATING SLEEVE	AT080-01	69	CABLE CLAMP	KP036-01
14	BEARING	FM005-01	41	SELF TAPPING SCREW	AF141-01	70	SCREW	IR133-01
15	BEARING CUP	AF007-01	42	GROMMET	AP071-01	71	BATTERY CLAMP	KP036-02
16	T/H BASE BLACK	AF004-07	43	CABLE TIE	AF030-01	72	FOOT PEDAL BASE	LP003-01
	T/H BASE WHITE	AF004-06	44	LAMP HOLDER	AF394-01	73	SHAFT BUSHING	KP021-01
17	#6 SELF TAP SCREW	EK135-01	45	LAMP	AF093-03	74	INSULATING SLEEVE	AT080-01
18	SCREW #8 X 3/4	LF141-03	46	NOMENCLATURE	CF056-13	75	6 X 1/2 SCREW	AF135-01
19	42/50" OUTER TUBE	AF165-06	47	BATTERY CABLE ASY	KP328-06	76	RETAINER PLATE	LP123-03
20	BEARING CUP	FM007-01	48	MICRO SWITCH BOOT	KP157-01	77	#10X1/2 SCREW	GR133-01
21	BEARING	FM005-01	49	#6 32 X 1 1/2 SCREW	LP135-01	78	ON SERT PAL NUT	TT098-03
22			50	MICRO SWITCH	AP151-01	79	E RING	FP046-01
23			51	6 - 32 NUT S.S	SP098-02	80	CABLE PIVOT PIN	AP105-01
24			52	MICRO BUTTON	LP026-01	81	CABLE PIVOT	LP091-01
25	CONE SET SCREW	AF143-01	53	FOOT PEDAL HI MARINE	LP101-03	82	.312 E RING	BK046-02
26	BEARING CONE	AF006-01	54	POTENTIOMETER	AP168-02	83	FOOT PEDAL ROCKER PIN	LP102-01
27	42".105 SS F/O COLUMN	AF049-09	55	LOCK WASHER 3/8	KP171-01	84	HI BYPASS DECAL	LP057-03
28	LOWER UNIT DECAL	AF060-07	56	GRIP RING	LP046-01	85	PINION NUT BUSHING	AF021-01

Model:
752V

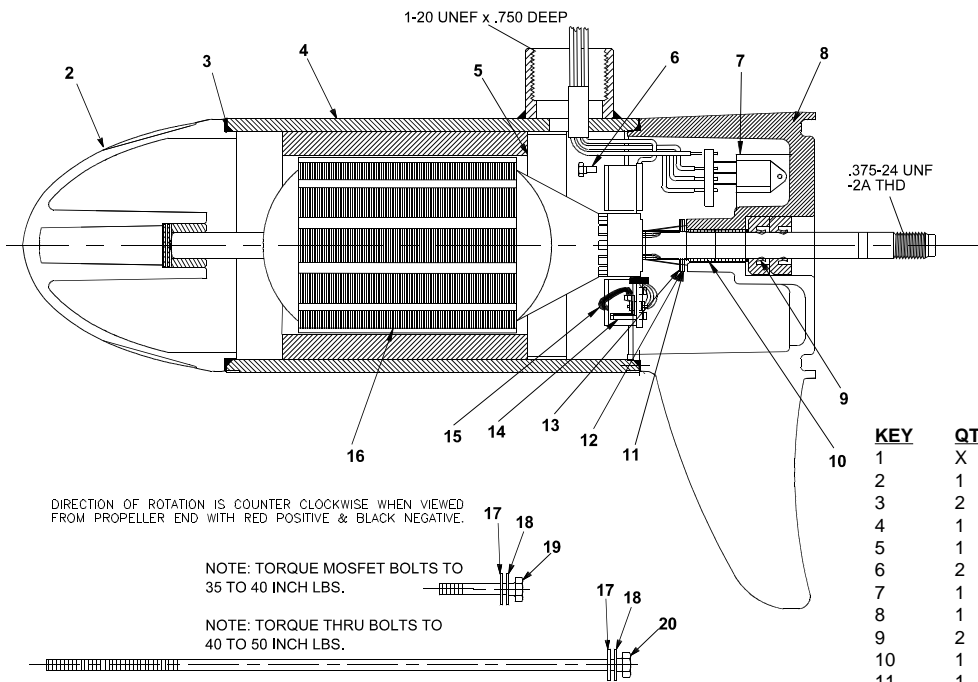

KEY	QTY	DESCRIPTION	PART NO.
1	X	MOTOR	CF397-16
2	1	NOSE CAP	XF3212-01
3	2	O RING SEAL	MR217-01
4	1	HOUSING ASY	UF3210-05
5	1	RETAINER	JF233-01
6	2	BRUSH CARD SCREW	MR228-01
7	1	DURA AMP MODULE	JF096-08
8	1	COMM CAP	XF3205-01
9	2	SHAFT SEAL	MR223-01
10	1	BEARING	MR206-01
11	1	NYLATRON WASHER	MR226-01
12	1	WASHER	MR227-01
13	1	E RING	MR219-02
14	2	BRUSH SPRINGS	MR214-02
15	1	BRUSH ASY LESS SPRING	UF3201-05
16	1	ARMATURE	CF3207-01
17	4	STATIC SEAL	MR222-01
18	4	THRU BOLT WASHER	MR216-01
19	2	DURA AMP SCREW	MR229-04
20	2	THRU BOLT	MR218-02

WIRING

